

2012 Canter: Body / Trailer Lighting Guidelines

If the completed truck will use only LED lighting (discarding the factory incandescent combination lamps), the SAM (Signal Actuation Module) must be programmed to control LED-type lamps via a Fuso diagnostic laptop at a port-of-entry or dealer. If this programming is not performed, a SAM code and rapid "bulb-out" flash rate of the TURN LAMPS will result due to low amperage draw of LEDs. Notice that the additional and maximum amperages shown are steady state amperages; the initial amperage draw of a cold incandescent filament is significantly higher than its steady state amperage due to the higher resistance of a hot filament.

Each left & right STOP/TURN/TAIL and the LICENSE PLATE lamp circuit must be utilized since they are monitored by SAM for minimum amperage draw per the attached chart.

If a circuit maximum amperage value is exceeded, the SAM will protect the circuit by shutting it down. Power to the circuit will be restored once the excessive load is removed from the circuit.

=====

Exterior Connections

TURN LAMPS

The two-wire "side turn" option connector shown in our 2012 BBD and copied below must also be turned on via the Fuso diagnostic laptop.

Logistically, and due to narrow amperage range requirements, this is not a viable connection at this time.

BODY MARKER/ID LAMPS

Per the chart, a connection to this wire at the three-pin harness (Green/White tracer wire) may be made with a load up to 8A (revised from 5A load originally indicated on p106 of BBD).

VAN BODY DOME LIGHT

Per the chart, a connection to this wire at the three-pin harness (Red wire) may be made with a load up to 5A. Van body dome light switch is standard equipment on the instrument panel.

TRAILER LIGHTING

If using chassis STOP/TURN/TAIL circuits to power trailer lamps, maximum additional amperage loads are as listed basis factory INCANDESCENT setting or optional LED setting. Generally, unless the trailer lights are LED type, the circuits on the chassis-cab must be used only for relay signal wires with dedicated fuse-protected load wires for the trailer lighting.

A 3-2 wire converter must be employed if a trailer or body will use a combined STOP/TURN lamp per side (generally the case for lighting systems which do not use a dedicated amber turn lamp per side).

If not using a mating connector from MFTA: The referenced wire needs to be cut (not removed) at the back of the connector and spliced into the body wire with a soldered and weatherproof sealed connection.

Note also that available wire length is short, so we recommend removal of the fender mud flap for improved access to exterior option connectors.

The MH056403, MH056401, MH050090 mating connectors for exterior lighting connections are available from your preferred MFTA dealer. (MFTA cannot sell any parts directly to an independent third party or end user.)

=====

Interior Connections

Please reference the attached 2012 BBD pages 102-104 for cab wire pass-through locations as well as optional connectors/positions.

The MH056874 6-pin/3-wire ("A" in the diagram) connector is taped to the radio harness with MAIN switched power at its Yellow/Green wire.

Our chassis-cabs do not have the 8-pin MH052847 "B" connector, but the MH056867 2-pin/1-wire "C" connector at the lower right side of the dash offers BATT power at its Red/Black wire.

Note that in all cases, the wire capacities are for SIGNAL-LEVEL amperages only , 1.0A maximum for controlling relay-protected load circuits.

The mating connectors MH056807, MH052805, MH056800 shown for interior connections are NOT available.

2012 Canter threshold amperage values

incandescent (factory) SAM parameter settings; all values in Amps				
STOP (#325)	standard	add'l max	total max	minimum
left side: 0.5mm ² Green	1.70	0.84	2.54	0.87
right side: 0.5mm ² Green/Red	1.70	0.84	2.54	0.87
TURN (#330)				
left side: 0.5mm ² Yellow/Blue	1.70	0.58	2.28	0.87
right side: 0.5mm ² Yellow/Red	1.70	0.58	2.28	0.87
TAIL (#320)				
left side: 0.5mm ² Blue	0.41	1.21	1.62	0.25
right side: 0.5mm ² Red	0.41	1.21	1.62	0.25
BACKUP (#340)				
left side: 0.5mm ² Black/Orange	3.50 (combined circuit)	2.00	5.50	n/a (not monitored)
right side: 0.5mm ² Black/Orange				
LICENSE PLATE (#320)				
left side: 0.5mm ² Orange/Blue	0.73	0.58	1.31	0.25

LED-type SAM parameter settings; all values in Amps				
STOP (#325)	standard	add'l max	total max	minimum
left side: 0.5mm ² Green	LED n/a	LED n/a	1.60 LED only	0.024
right side: 0.5mm ² Green/Red			1.60 LED only	0.024
TURN (#330)				
left side: 0.5mm ² Yellow/Blue	LED n/a	LED n/a	0.74 LED only	0.024
right side: 0.5mm ² Yellow/Red			0.74 LED only	0.024
TAIL (#320)				
left side: 0.5mm ² Blue	LED n/a	LED n/a	1.60 LED only	0.024
right side: 0.5mm ² Red			1.60 LED only	0.024
BACKUP (#340)				
left side: 0.5mm ² Black/Orange	LED n/a	LED n/a	5.50 LED or INC	n/a (not monitored)
right side: 0.5mm ² Black/Orange				
LICENSE PLATE (#320)				
left side: 0.5mm ² Orange/Blue	LED n/a	LED n/a	1.31 LED or INC	0.25

TAIL, POSITION AND LICENSE PLATE LAMPS CIRCUIT

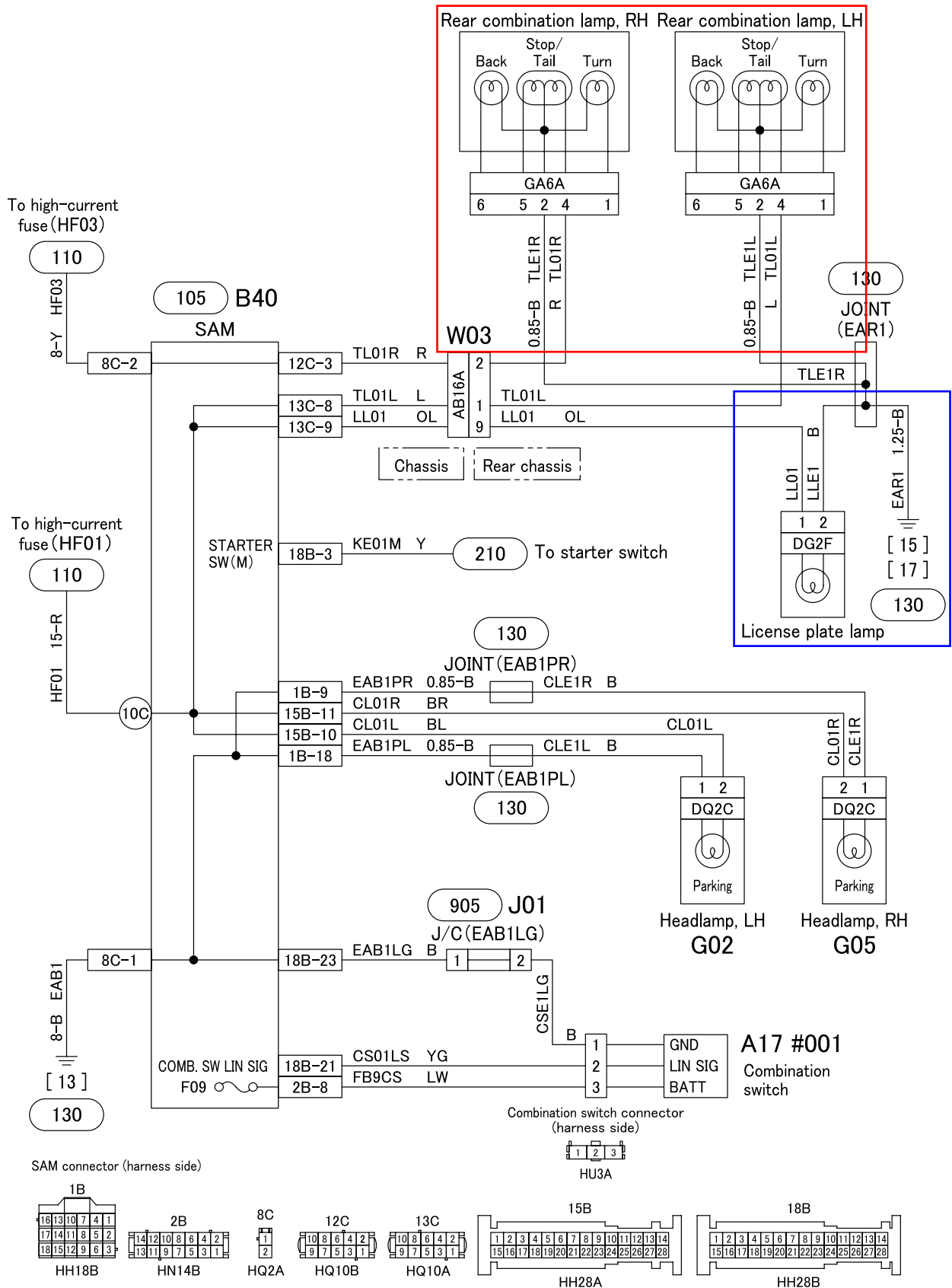

320-C07348

- (s) When passing electrical wiring through the cab floor, use the grommets in the area A and B shown in Fig. 4.

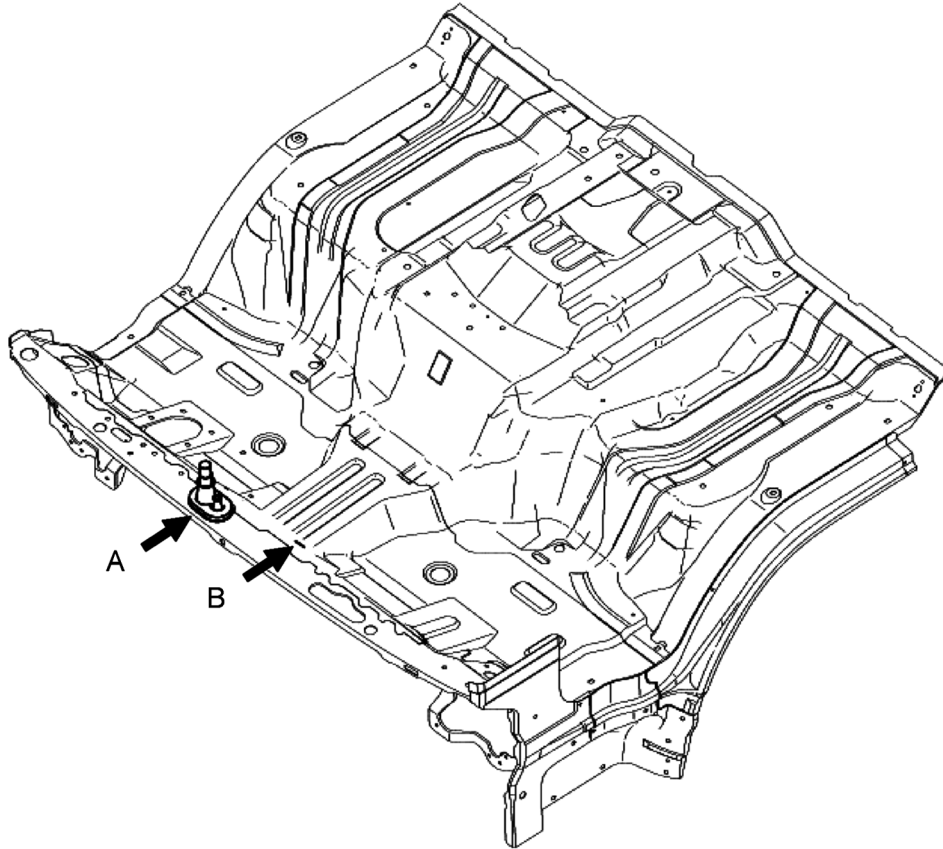
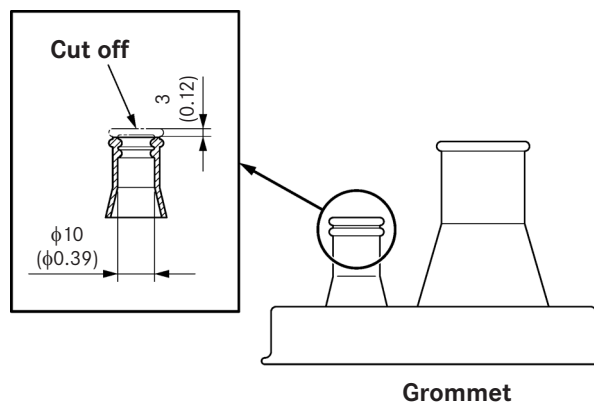

Fig. 4

Let harness pass through the grommet cut as shown in Fig. 5 and then tape them.



Unit: mm (in.)

Fig. 5

6 Modifications to the basic vehicle

6.12 Electrics/electronics

- Mounting Location of Optional Terminal Inside Cab

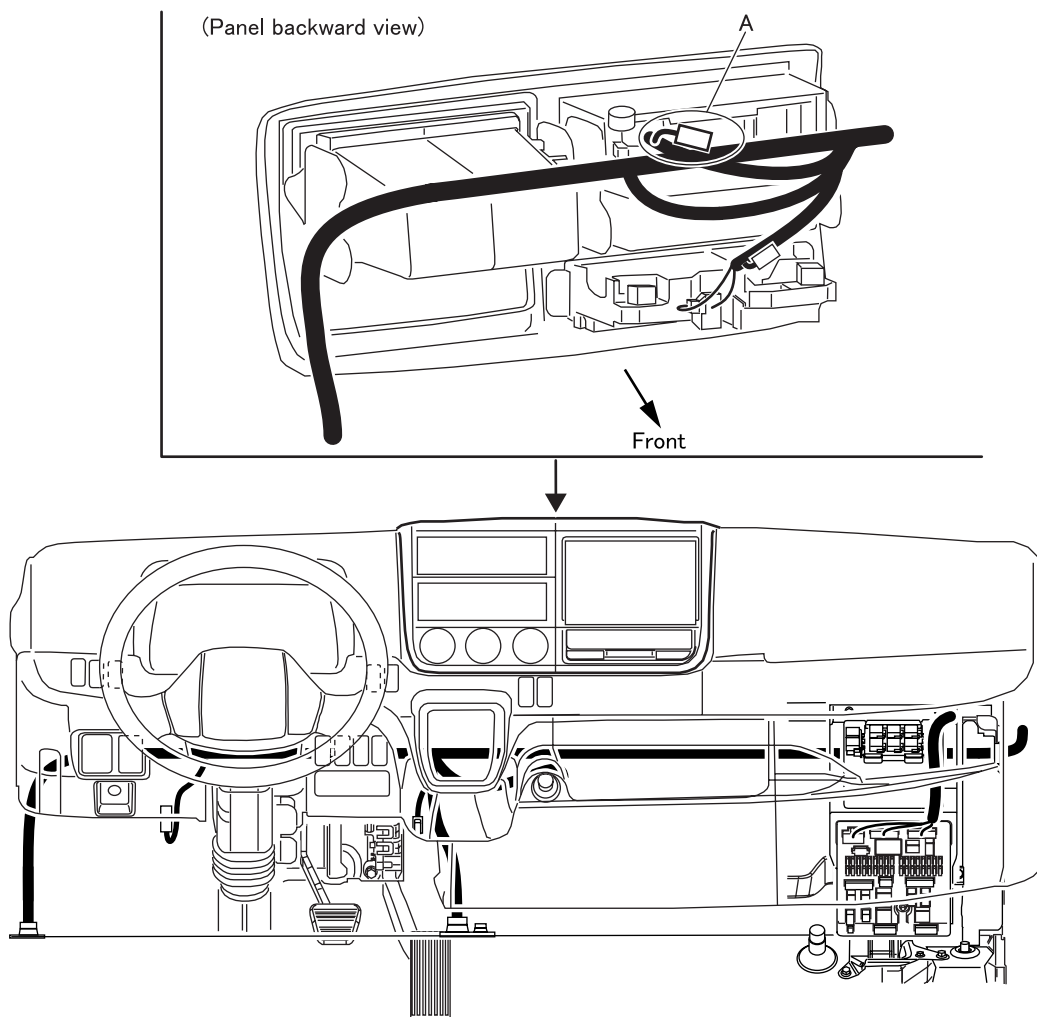

No.	Part Name	Connector No.	Circuit Description				Mating Connector
			No.	Circuit	Line color	Load	
A	OPTION CONNECTOR (Tachograph navigation)		01	MAIN (12V)	Y-G	-	
			02				
			03				
			04				
			05	SPEEDSIG(25P)	Lg	-	
			06	SPEEDSIG(8P)	O-L	-	

-: The connector marked with - is used for signal cabling only, not used to connect the loads.

6 Modifications to the basic vehicle

6.12 Electrics/electronics

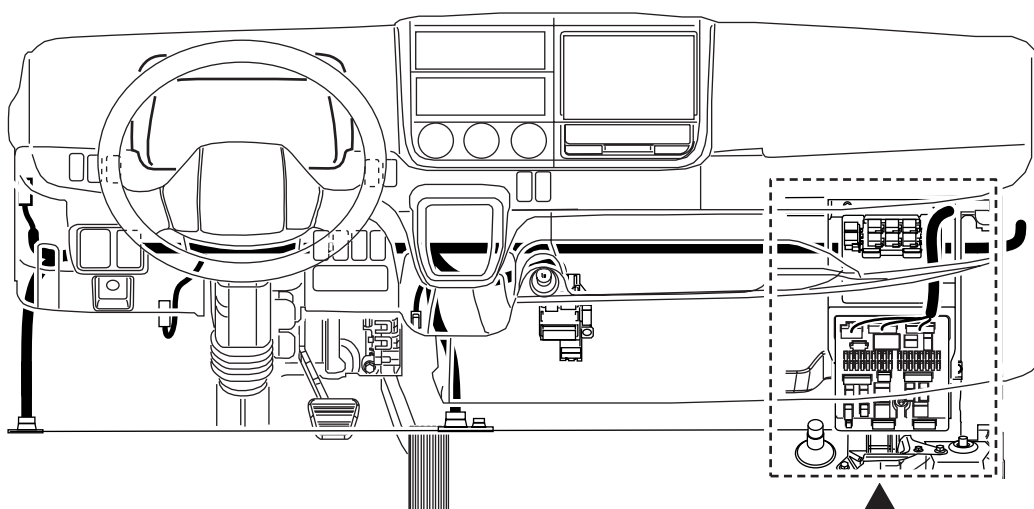

Sub harness MK649751 with option connector B is not factory installed, but can be ordered from an MFTA dealer. Once connected to SAM, the harness provides battery voltage at each of the indicated pins: 1-5,7,8 for each switched event or start key position as described (to be used for relay control signaling at 1.0 amp maximum per circuit).

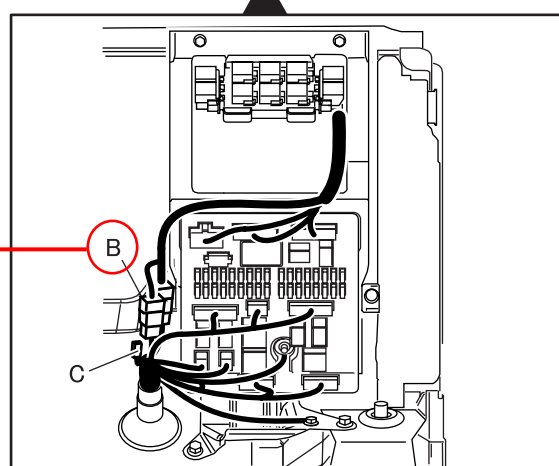

No.	Part Name	Connector No.	Circuit Description				Mating Connector
			No.	Circuit	Line color	Load	
B	OPTION CONNECTOR (Only When sub harness (MK649751) is arranged) available from MFTA dealer	MH052847 	01	PARKING ON	Br	*1	MH052805 not available
			02	NEUTRAL	R-G	*1	
			03	PTO	Lg-R	*1	
			04	ILL	O-B	*1	
			05	MAIN	L-R	*1	
			06	GND	B	10A	
			07	BATT	G-R	*1	
			08	ACC	W-R	*1	
C	OPTION CONNECTOR	MH056867 	01	IDLE UP	R-B	-	MH056800
			02	(SWtoGND)			

-: The connector marked with - is used for signal cabling only, not used to connect the loads.

*1: Loads to be connected to the connector marked with *1 should be arranged so that the total value of the connector output in each of the cab and chassis side shall not exceed the permissible current.

6 Modifications to the basic vehicle



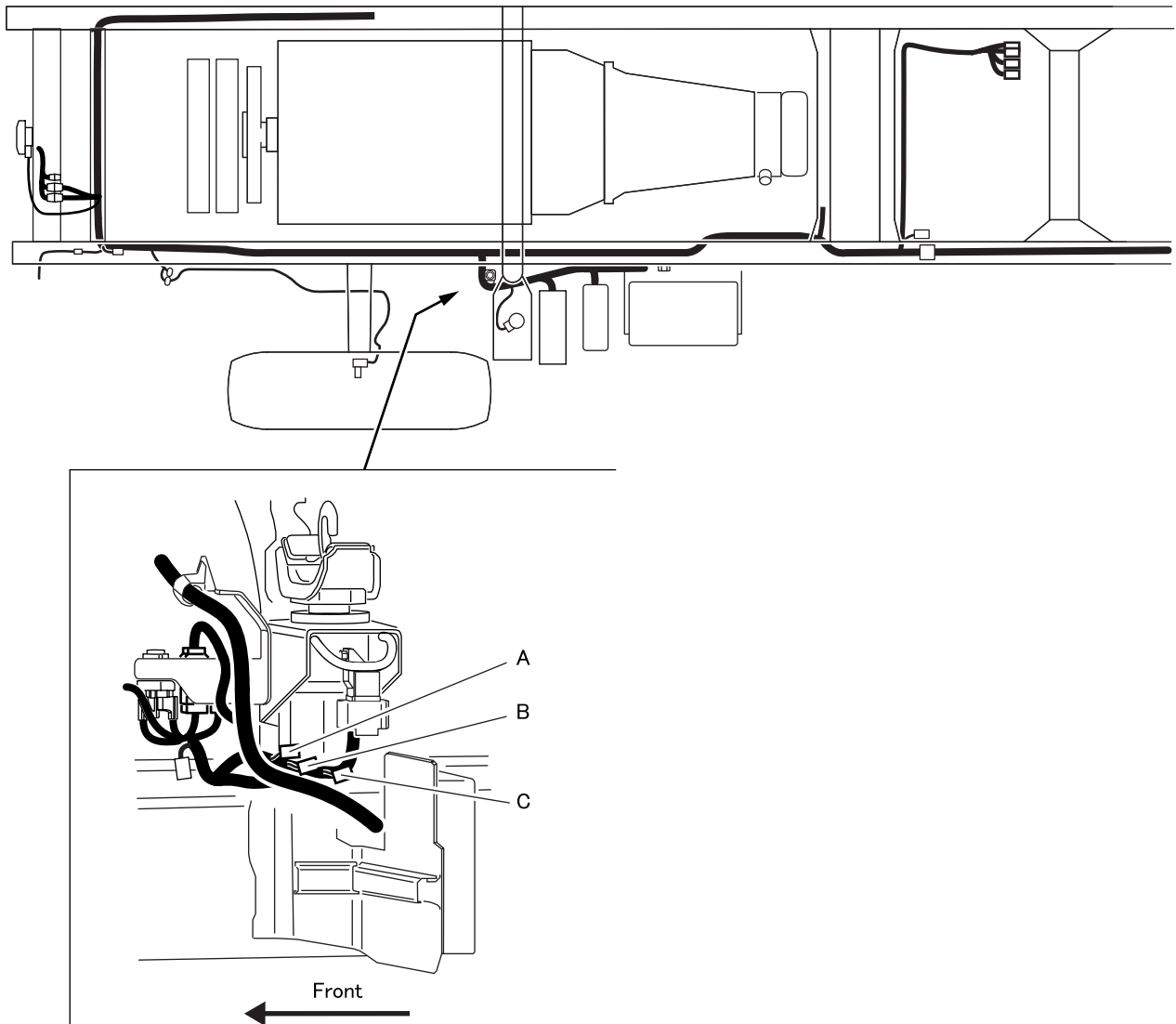

6.12 Electrics/electronics

- Mounting Location of Optional Terminal Outside Cab

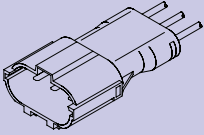

6 Modifications to the basic vehicle

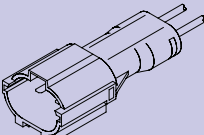
6.12 Electrics/electronics

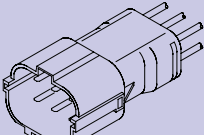
No.	Part Name	Connector No.	Circuit Description				Mating Connector
			No.	Circuit	Line color	Load	
A	OPTION CONNECTOR (van room lamp & ID lamp)	MH056453 	01	VAN ID LAMP	G-W	8A	MH056403 
			02	GND	B	9A	
			03	VAN ROOM LAMP	R	5A	
B	OPTION CONNECTOR (side turn) REQUIRES CIRCUIT ACTIVATION BY FUSO DIAGNOSTIC LAPTOP	MH056451 	01	TURN LH	Gr-L	*1	MH056401 
			02	TURN RH	Gr-R	*1	
C	OPTION CONNECTOR (chassis)	MH056457 	01	BATT	G-R	*2	MH050090 
			02	ACC	W-R	*2	
			03	MAIN	L-R	*2	
			04	IDEL UP	R-B	-	
			05	ILL	O	-	
			06	GND	B	-	

-: The connector marked with - is used for signal cabling only, not used to connect the loads.

*1: In a vehicle with a connector marked with *1, one lamp as shown in the following can be additionally mounted for one side of the vehicle at manufacturer's option: voltage: 12 V, lamp type: 21 W.

*2: Loads to be connected to the connector marked with *2 should be arranged so that the total value of the connector output in each of the cab and chassis side shall not exceed the permissible current.